

AMO Automatisierung
Messtechnik Optik GmbH



**Inductive Angle Measuring System
for highest accuracies**

MHS-21x

Multiple Head Solution



- **Eliminates eccentricity and run out error**
- **Accuracies till 2 Arcseconds**

Description of Multi Head Scanning

Possible sources of errors

On a detailed view of possible sources of error on a rotary axis one encounters the following errors:

A. Systematically, repeatable errors per revolution

- Eccentricity from measuring flange with respect to the axis of rotation
- Grating errors of the measuring scale as deviation from an ideal grating
- Run out errors from the bearing

B. Coincidental errors

- Backlash of the bearing
- Load-sensitive deformation

Compensation of the eccentricity:

Since the systematically errors specified above are in practice not completely avoidable, we present an economic compensation possibility.

In principle by the use of several reading heads (e.g. 2 or 4 heads) the eccentricity error is eliminated and systematically errors are reduced by a factor 2 or 4 is reduced, as described in the following.

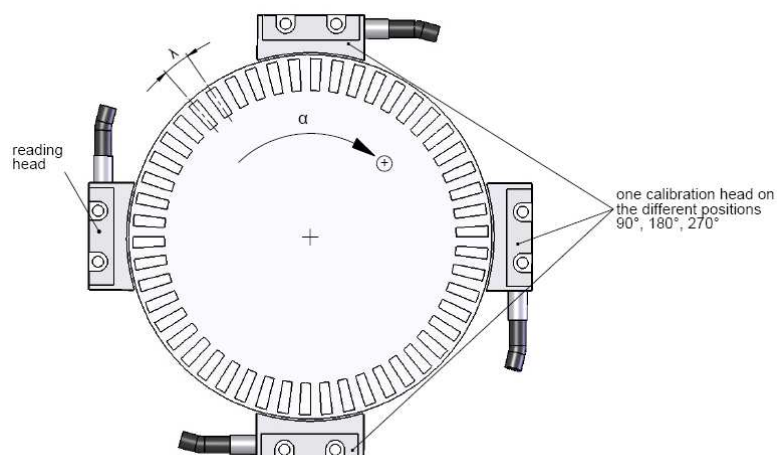

Figure 1: Arrangement for multi head scanning

Multi Head Scanning- with CHS-11x

The AMO rotary encoder **CHS-11x** is designed for high accuracy applications, where precision bearings are used which are backlash free (pre-tensioned in mounting). Therefore, most of the measuring errors are systematic and repeatable, and the non-repeatable errors for the majority of applications can be neglected.

The measuring system consists of a measuring flange, a reading head, an evaluation electronics box and a calibrating head as shown in figure 2 below.

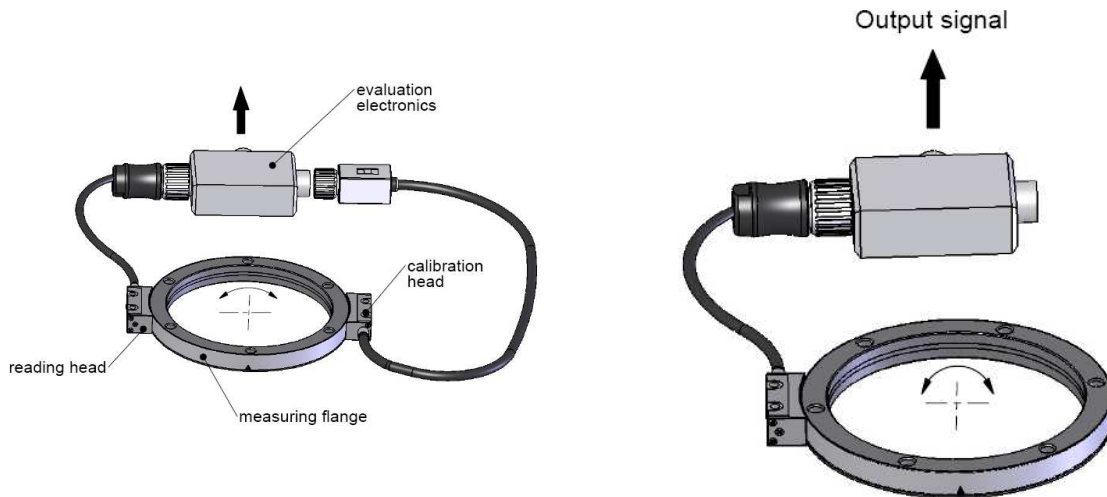

Fig. 2a: arrangement during calibration

Fig. 2b: arrangement for operation

During the calibration procedure, the calibrating head is temporarily mounted diametrically opposite (180°) to the active measuring head.

During a rotary movement of the measuring flange collecting and transmitting of the position data from both heads starts when the reference mark passes the reading head. The calibration procedure for this position of the calibration head is completed after one revolution and the error deviations are stored in the evaluation electronic box.

For the quadruple encoder head calibration procedure, which results in an even higher accuracy, the calibration head must be mounted successively in the positions 90° and 270° . After the third calibration procedure at position 270° the calibration is done.

Consequence: The eccentricity error is completely eliminated and the influences of systematic errors is reduced by a factor of 2 (by using a **CHS-11x** or **MHS-21x**) and/or 4 (by using a **CHS-11x**).

The great advantage of the **CHS-11x** is that only one reading head is used for normal operation, offering highest accuracy similar to a double and/or quadruple reading head design but with lower system costs.

Metrological considerations

To illustrate the accuracies that can be reached with the MHS or CHS are given further measuring diagrams of a system WMI-101-1024 (see brochure or www.amo-gmbh.com) which is a standard angle measuring system with a grating ring of about 326 mm diameter and an accuracy of $\pm 6''$ for a standard single head encoder under ideal mounting conditions, that means no eccentricity.

Standard single head encoder

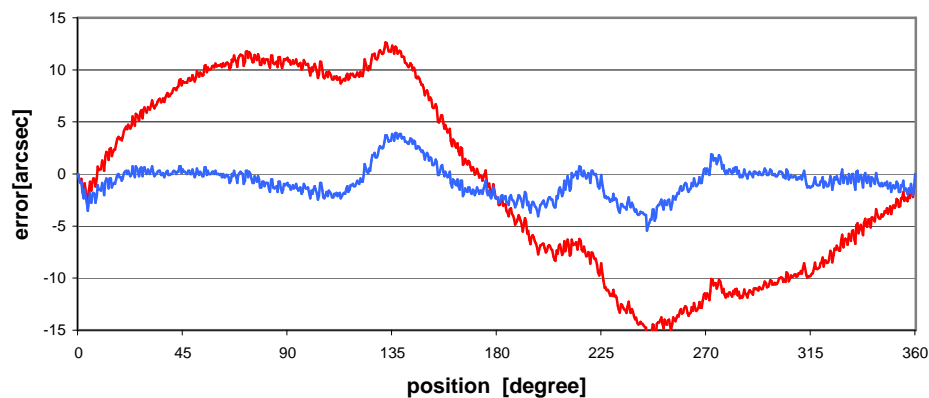

blue graph:

standard single head encoder under ideal mounting conditions for the measuring flange (no eccentricity; $e=0$)

red graph:

same standard single head encoder, but measuring flange mounted with an eccentricity of $10\mu\text{m}$

Dual head encoder system MHS-21x or CHS-11x with 2 head calibration

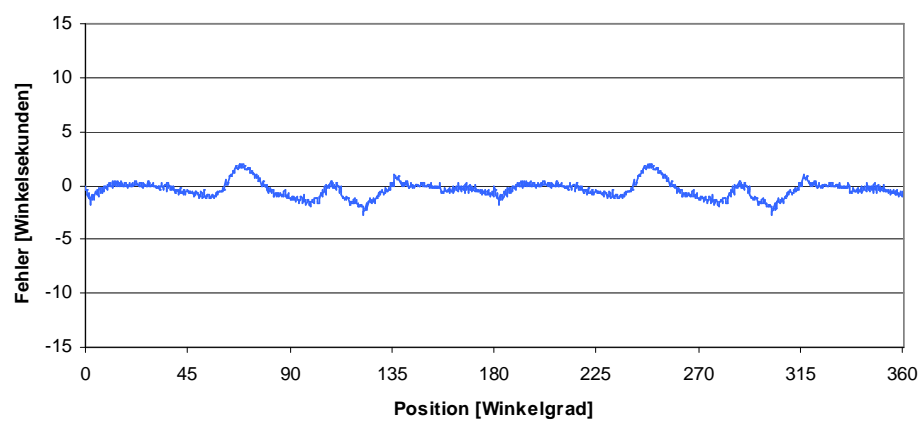

Compensation of eccentricity and a 2 times higher accuracy of $\pm 3,2''$ compared with the standard single head encoder as shown above.

CHS-11x with 4 head calibration

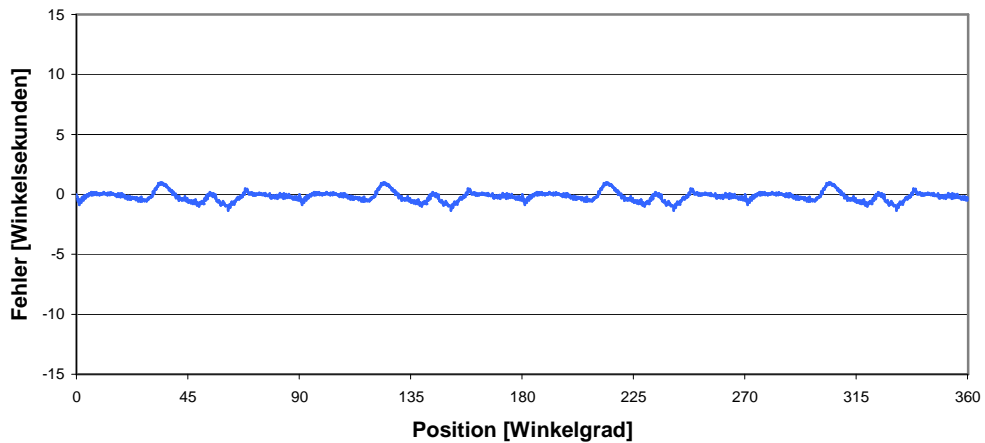

Compensation of eccentricity and a 4 times higher accuracy of $\pm 1,6''$ compared with the standard single head encoder as shown above.

Absolute accuracy for a rotary axis with AMOSIN rotary encoder

Size of measuring flange/ measuring ring	Outer diameter [mm]	System accuracy	System accuracy	System accuracy
		standard single head encoder [arcsec]	dual head scanning MHS-21x or 2-head-calibration CHS-11x [arcsec]	4-head-calibration – CHS-11x [arcsec]
512	163,0	12,0	6,0	3,0
720	229,2	9,0	4,5	2,2
900	286,5	7,0	3,5	1,7
1024	325,9	6,0	3,0	1,5
1440	458,4	4,5	2,2	1,1
2048	651,9	3,0	1,5	0,8

System configuration

„Dual head“ operation

- Measuring flange **WMF-10x-xxxx-x** or measuring ring **WMR-10x-xxxx-x**
- Two scanning heads **WMK-xx0-xxxx-x-6**
- **MHS-21x.xx**

In this configuration with two scanning heads the position signal from both scanning heads is read, evaluated and available at the output as analog or digital signal, depending on the desired interface.

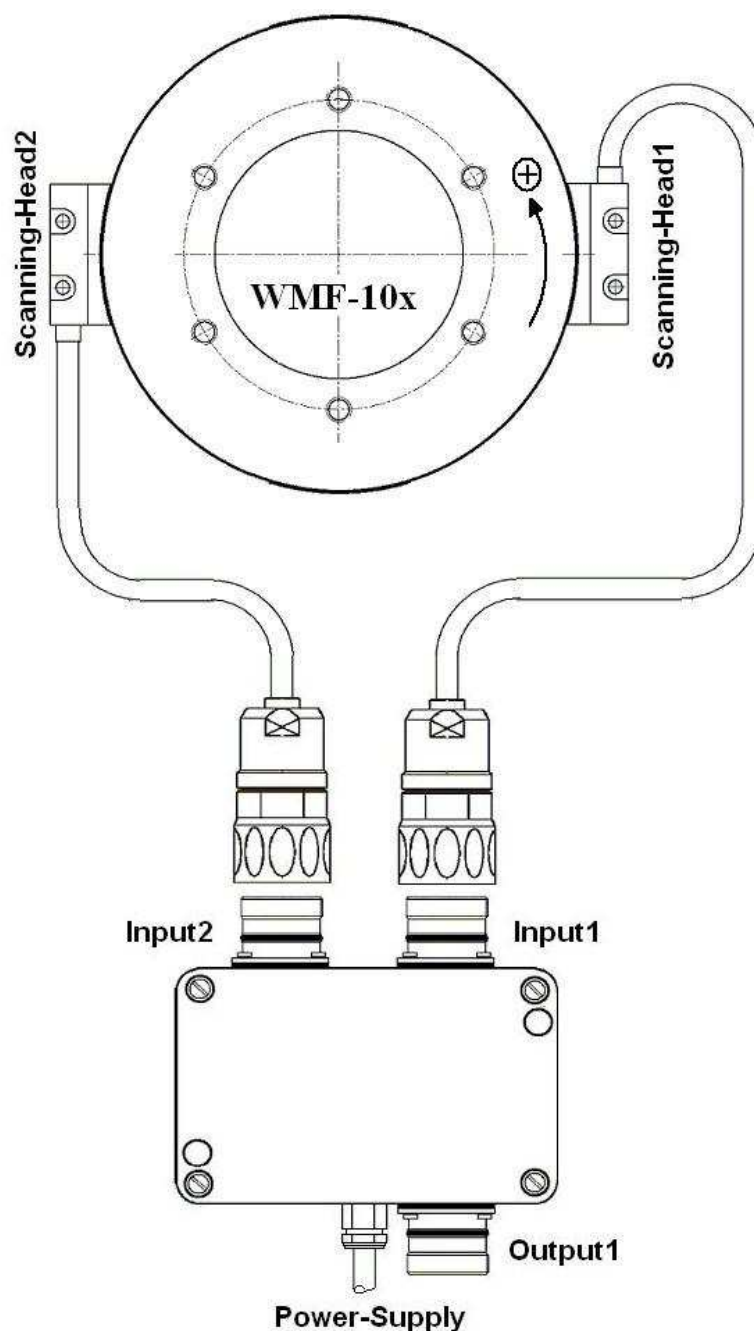

Technical data:

Operating temperature:	-10°C to 100°C (higher temperatures by request)
Storage temperature:	-20°C to 100°C
Protection class:	IP 67
Power supply:	+24V (7 ÷ 36V) 180mA. Power supply over a separate cable with 3m length
Cable:	PUR jacket, high flexibility, Ø 5,3mm, 5(2x0,05) + 1 (2x0,14) mm ² Bending radius: 10 x d = 50mm continuous bending 5 x d = 25mm single bend
Output signals/ system resolutions:	<ul style="list-style-type: none"> • Output analog 1Vpp (divided) Possible dividing factors D = 25 or 32 Total number of sinusoidal periods at the output: N' = N x D • OutputTTL (RS422): Digital interpolation factor I = 256 or 1024
Max. speed:	Refer to the following frequency/rotational velocity table

Type	Output signal	Max. input frequency f [kHz]	Rotary speed n [rpm]		
			For typical measuring flange WMF-100-N ³⁾		
			720	900	1024
MHS-211.1	1 V _{SS}	10	800	640	550
MHS-212.2	TTL / I = 256	10	800	640	550
MHS-212.3	TTL / I = 1024	2,5	200	160	130

³⁾ ... other sizes for measuring flanges see brochure "**Angle measuring systems based on the AMOSIN – Inductive Measuring Principle**"; with measuring rings WMR up to 8000 grating pitches/rev possible

Otherwise the following applies:	
<ul style="list-style-type: none"> • Maximum speed: $n_{max}[rpm] = f [Hz] \times 60 / N$ (grating pitches/revolution) • Output frequency (frequency limit for the subsequent electronics) MHS-211: $f_a = f \times D$ [kHz] MHS-212: $f_a = f \times I$ [kHz] Max. value: 320kHz for type MHS-211.1† (This max. values may not be exceeded!!) 	<p>N grating pitches / revolution D analog dividing factor (D = 25 or 32) I digital interpolation factor (I = 256 or 1024)</p>

Dimensions

Measuring scale

The measuring scale is specified in the brochure “**Angle measuring systems based on the AMOSIN – Inductive Measuring Principle**”

Scanning head WMK-1050

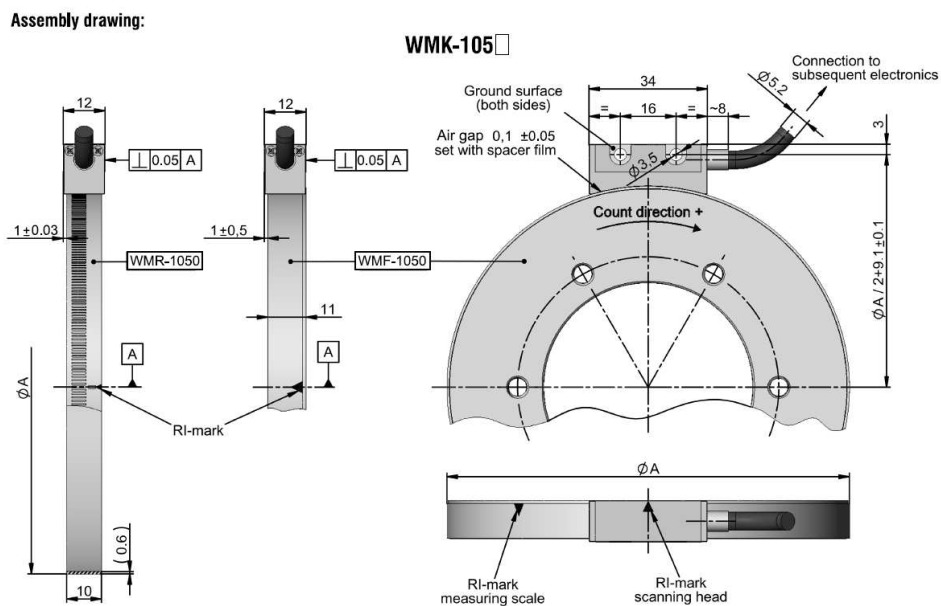

The dimensions for WMK-100 and WMK-300 are specified in the brochure “**Angle measuring systems based on the AMOSIN – Inductive Measuring Principle**”

MHS

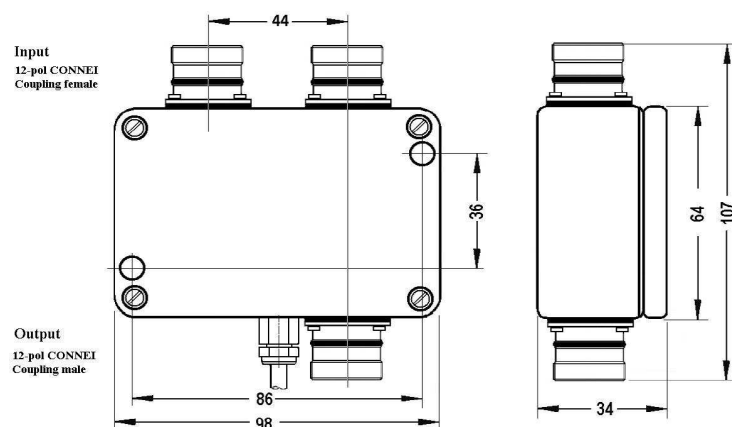

Description of the output signals

Output signals 1Vpp

Recommended configuration of the subsequent electronics:

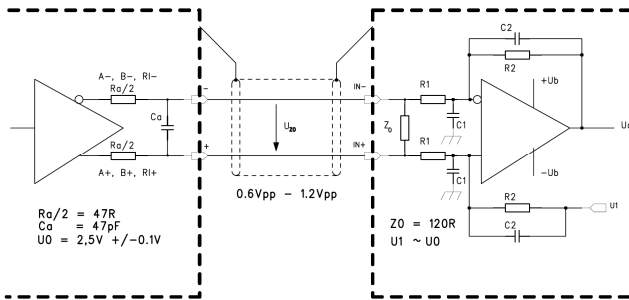

- **A+,B+,RI+ (and their inverted signals)**
direct signal output with dividing factor $D = 1$
- **A'+,B'+,RI'+ (and their inverted signals)**
divided signal output with dividing factor $D \neq 1$

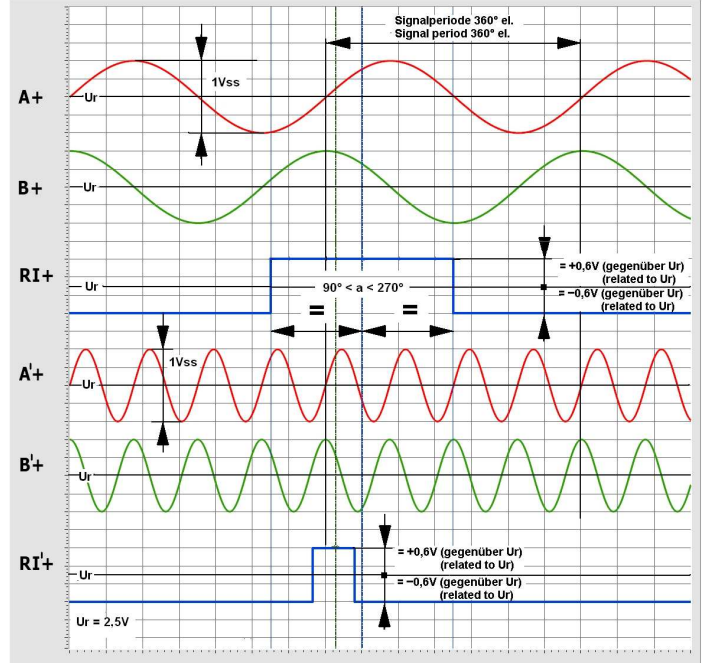

Output signals TTL – RS422

Recommended configuration of the subsequent electronics:

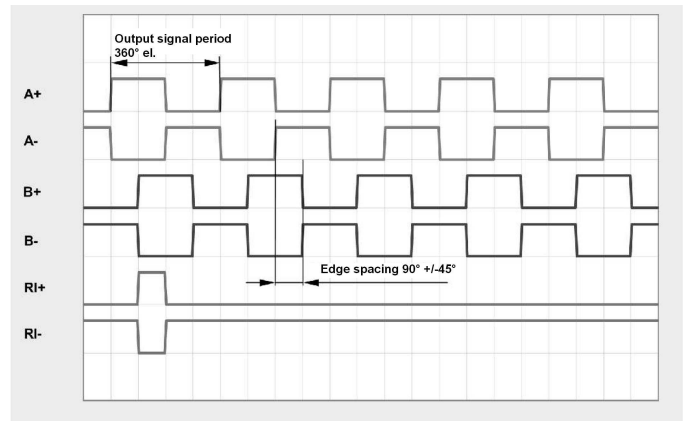
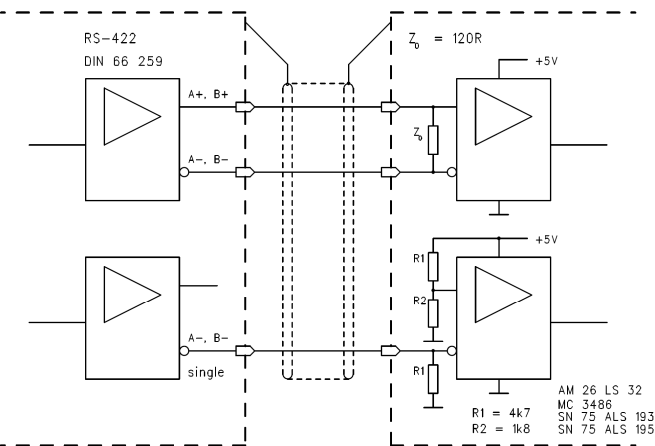

Ordering code

Measurement system consists of:

1. Two scanning heads of type WMK-1050 or WMK-100 or WMK-300
2. MHS-21X evaluation electronics

**1) Scanning head WMK-1050 or WMK-100 or WMK-300
(depends on the desired grating pitch)**

WMK-1050 - xxxx - x - 4

WMK-100 - xxxx - x - 4

WMK-300 - xxxx - x - 4

Connector

12 pin. CONNEI connector

Cable length (integer number in meter)

1 ... 1m (preferred length)

3 ... 3m (preferred length)

X ... spezial length (requires a spezial no. Sxx)

Grating pitches / revolution (N)

2. Evaluation electronics MHS

Analog 1Vpp

MHS- 2 1 1 . 1 †

Output signal 1Vss:

Analog dividing factor (D)

3 ... 25-fach

4 ... 32-fach

max. input frequency

1 ... 10 kHz

Number of outputs

1 ... one output **STANDARD**

(additional output as an option by request)

Digital TTL/RS422

MHS- 2 1 2 . †

Output signal TTL

Interpolation faktor (I)

2 ... 256

3 ... 1024

max. input frequency

10,0 kHz

2,5 kHz



Spannungsversorgung

24V (via a separate cable)

Plug and connection assignments (system output)

CONNEL connector adv. coupling 12-pin
 Sinus 1Vpp or square-wave output signals TTL

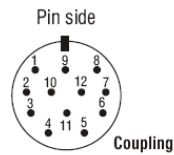

Pin	1	2	3	4	5	6	7	8	9	10	11	12
Signals	B-	-	RI+	RI-	A+	A-	-	B+	-	0V	-	-
Color	white	-	pink	grey	green	yellow	-	brown	-	blue	-	-

Shield on housing

Power supply

The MHS is supplied over a separate cable (length = 3m)

Signal	+24V	0V
Color	brown	white

Notice

Additional Informations



**AMO Automatisierung
Messtechnik Optik GmbH**

Nöfing 4
A-4963 St. Peter/Hart

Tel: +43 / 7722 / 65856 - 10

Fax: +43 / 7722 / 65856-11

Email: office@amo.at

Homepage: www.amo-gmbh.com